

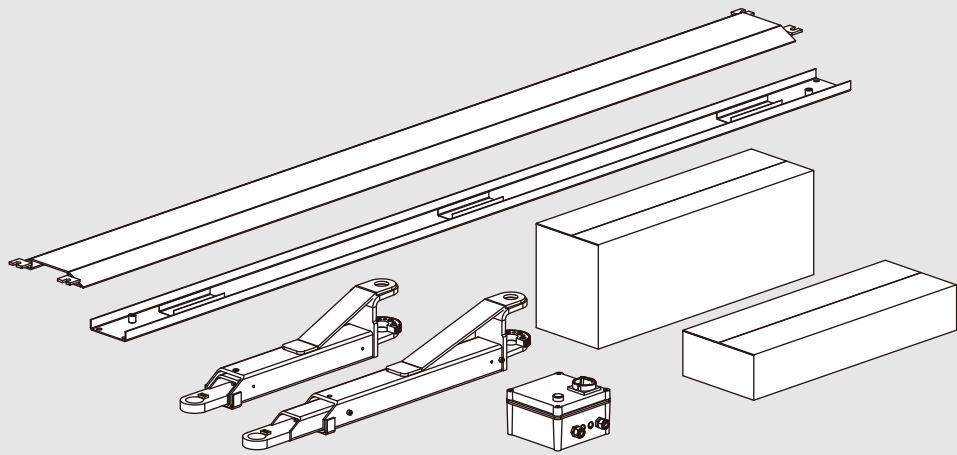

ELECTRO-HYDRAULIC 2-POST LIFT

L-2040D ASSEMBLY MANUAL

Ver.19.9.1



Step 1

To disassembly the package and remove all components and accessories.

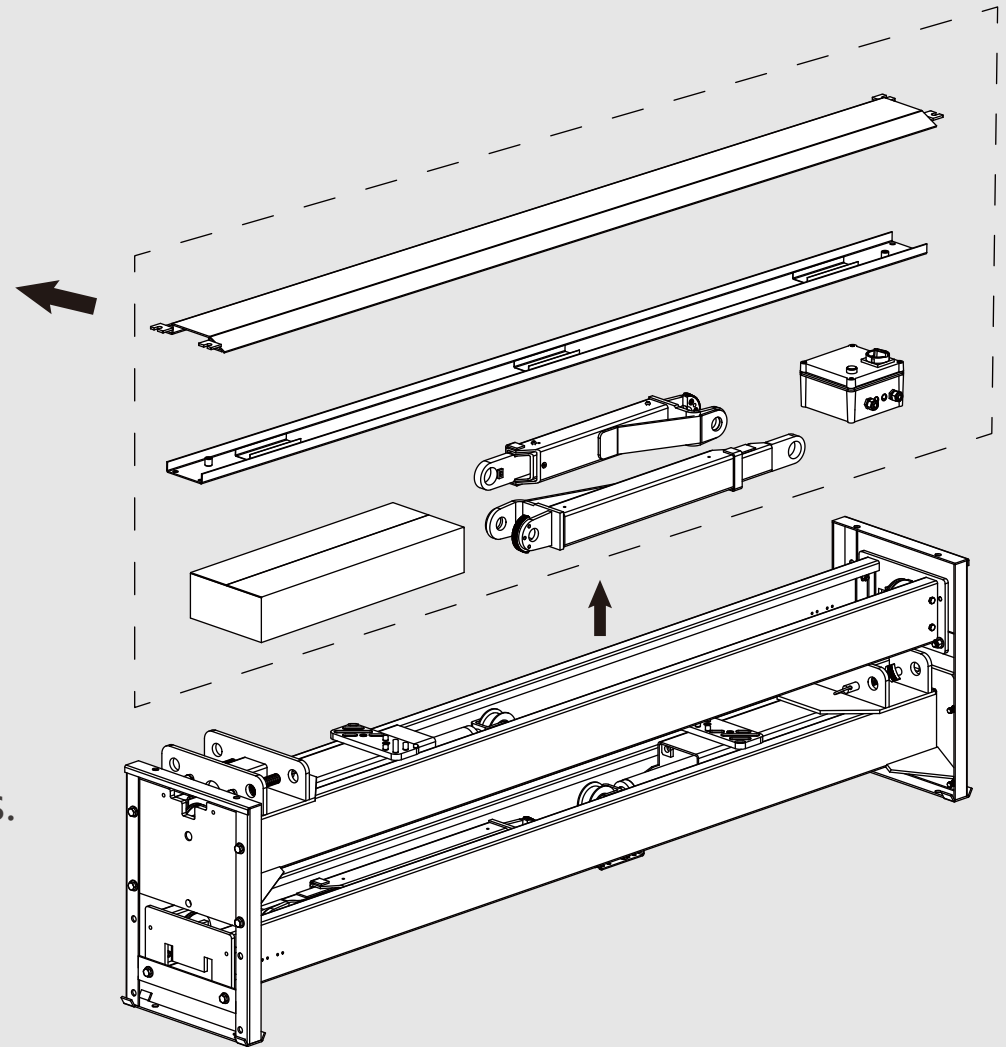

Step 2

To remove fixing bolts of packing brackets.

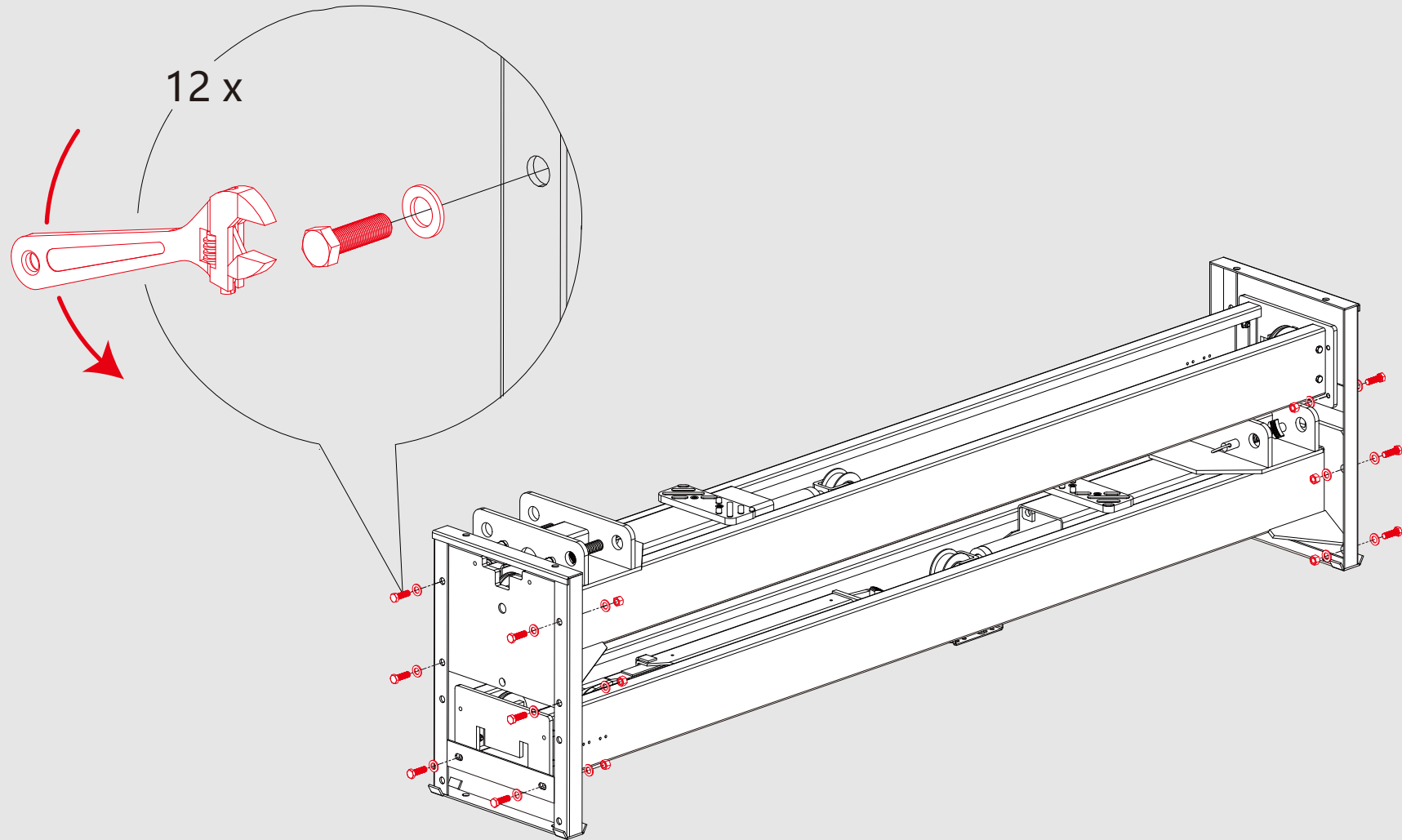

Step 3

To move two columns to install area.
Pay attention: to recognize and decide
command and slave column' s position
to install.

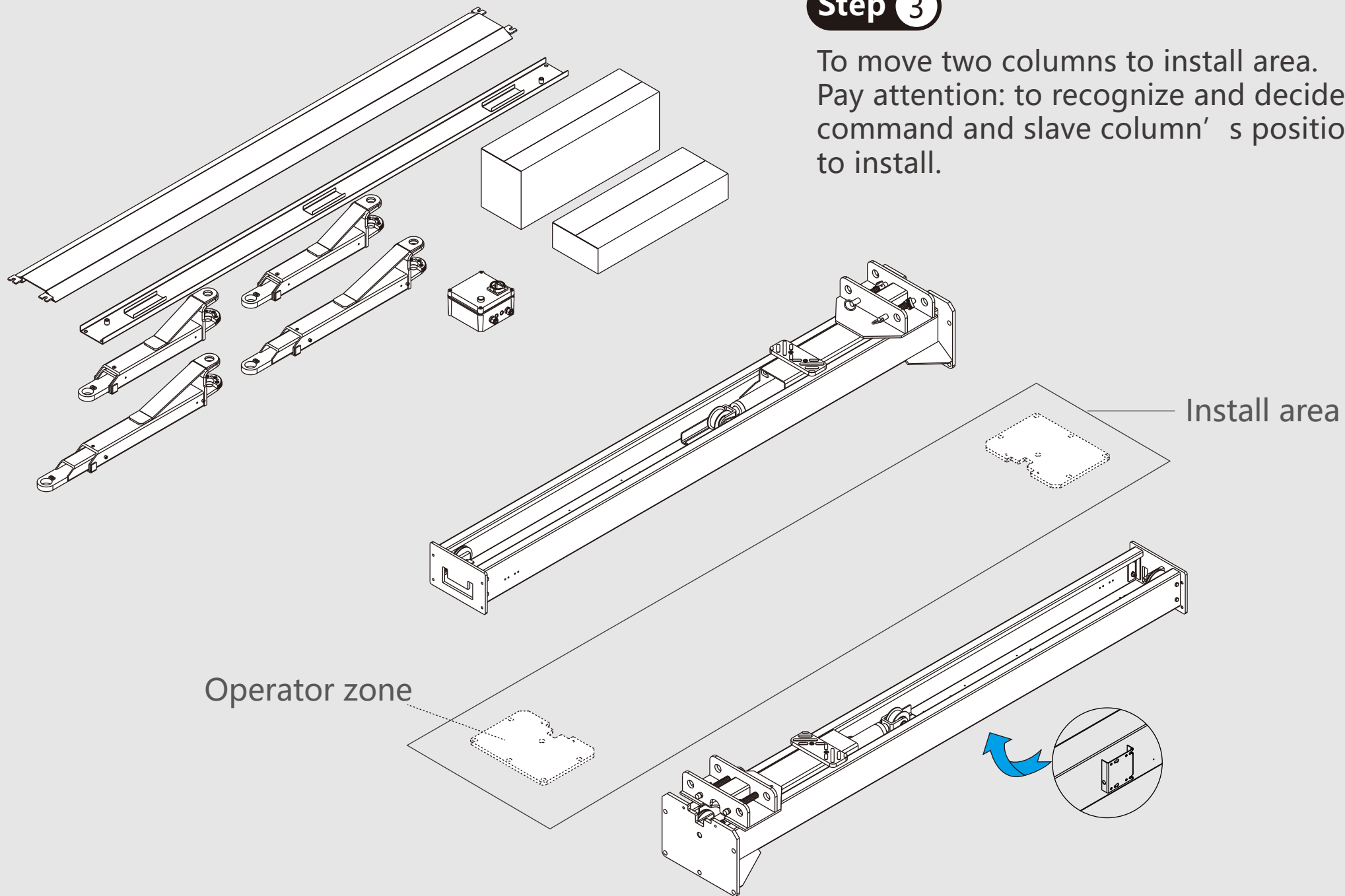

Step 4

To lift up two columns.

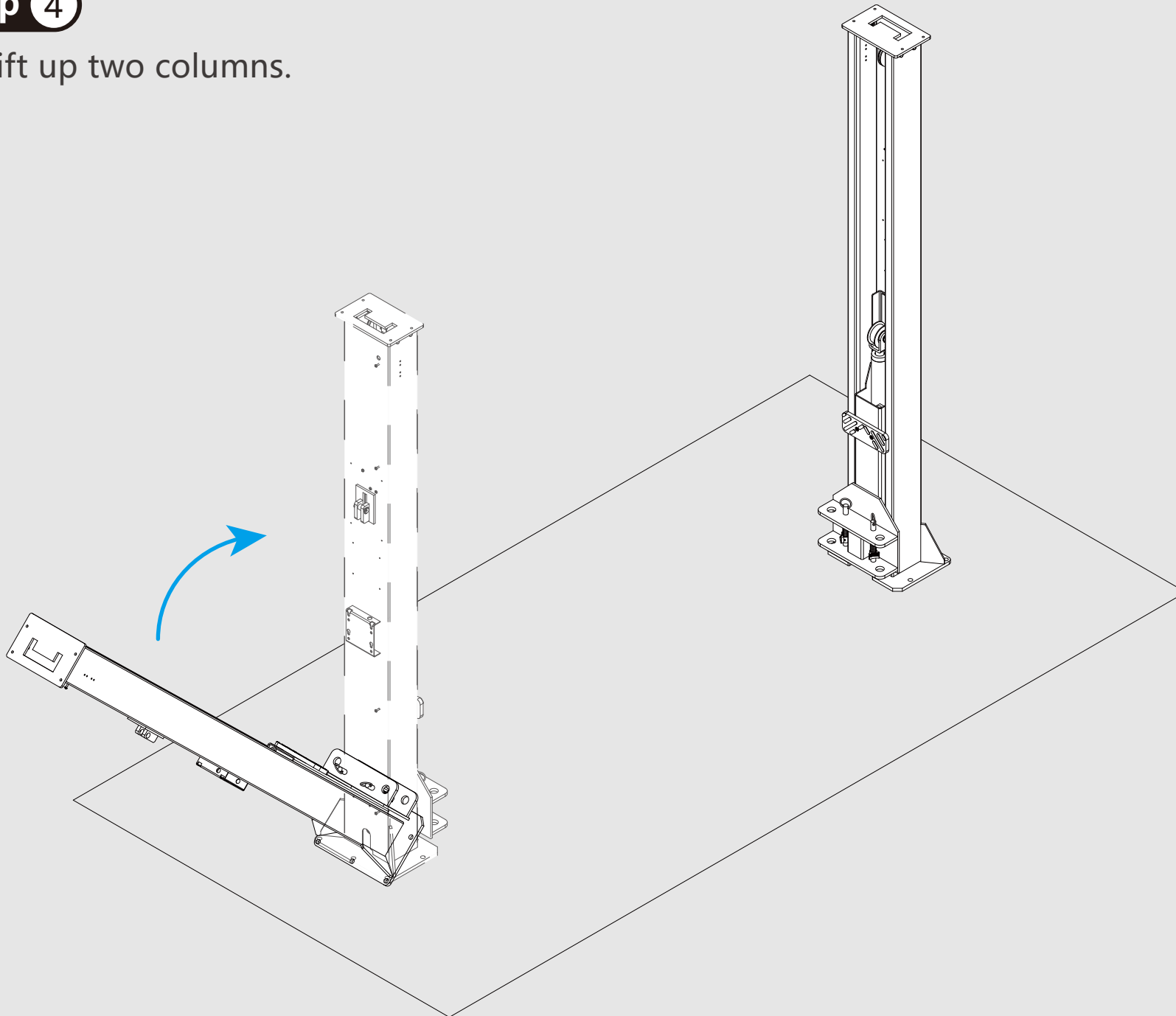

Step 5

To measure the distance of two columns,
and two columns face each other accurately.

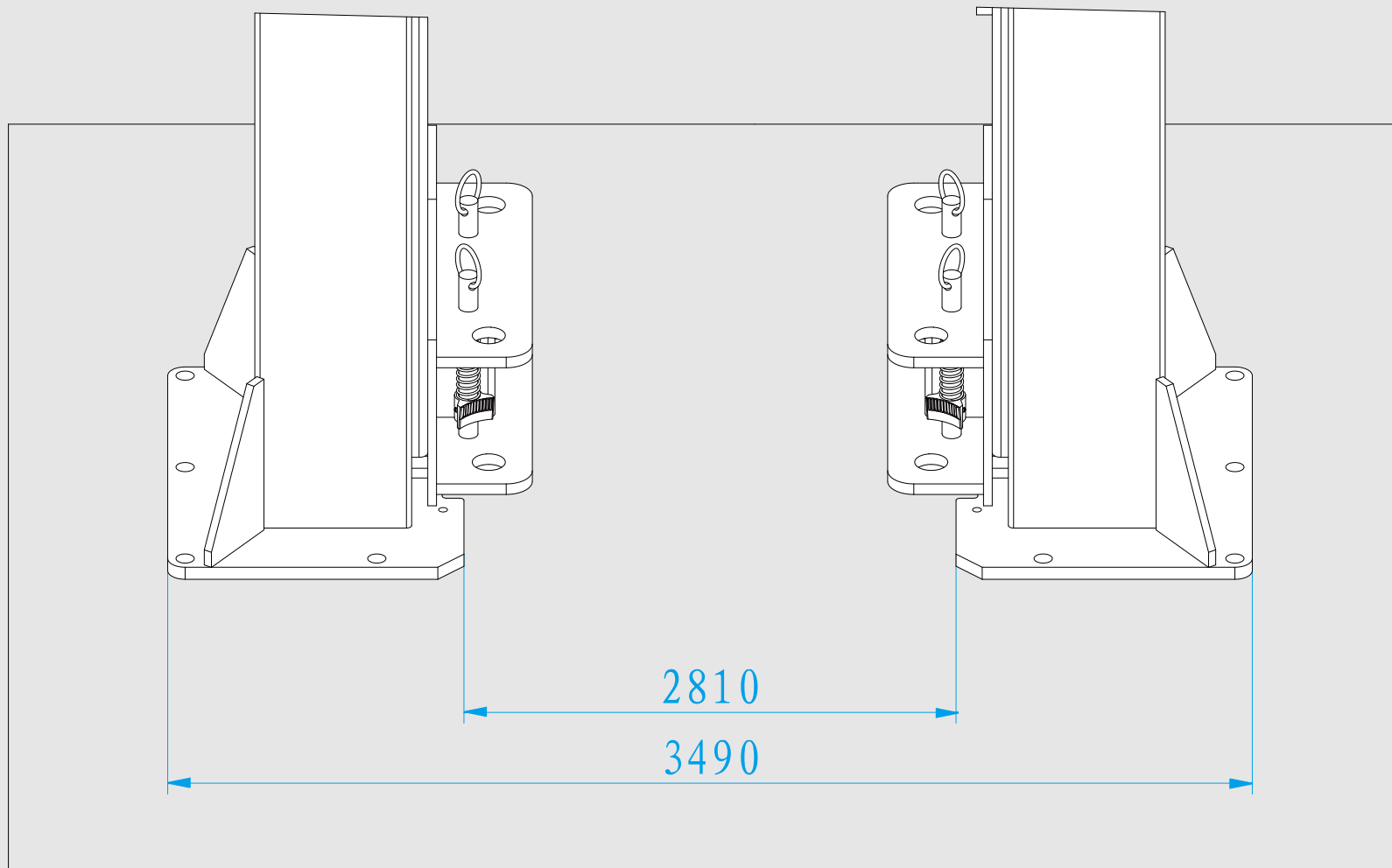

Step 6

To fix well columns.

- 1 Percussion drilling chopping bit 18.5mm depth 150mm

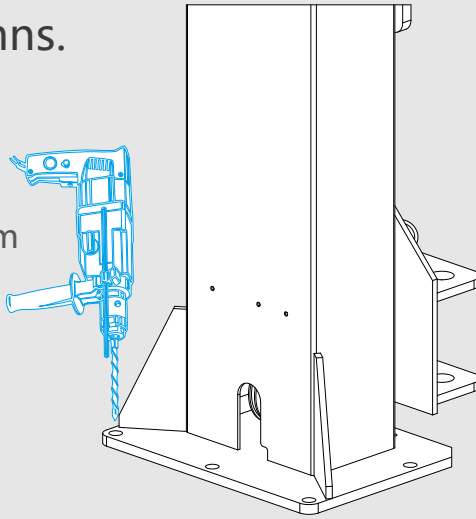

- 2 Air purge to remove dust inside of hole.

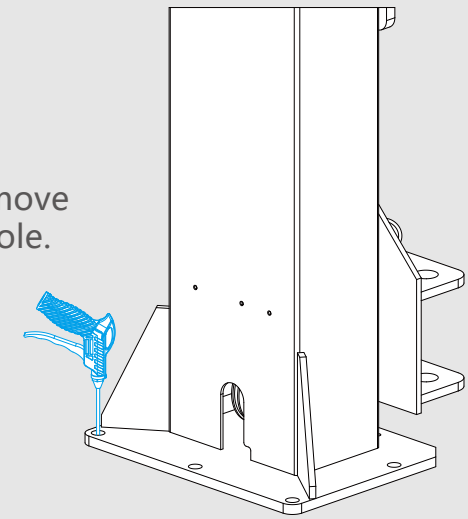

- 3 Insert bolt with bushes and screw nut, not to tighten to death, insert bushes under the column baseplate to adjust, by aid of spirit level measurement to make column to be vertical at 90°.

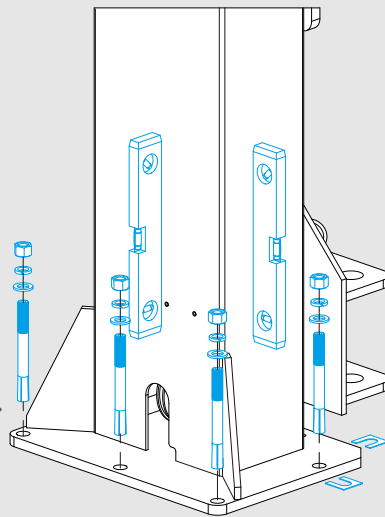

- 4 Insert long pin with hammer to hit in to the end.

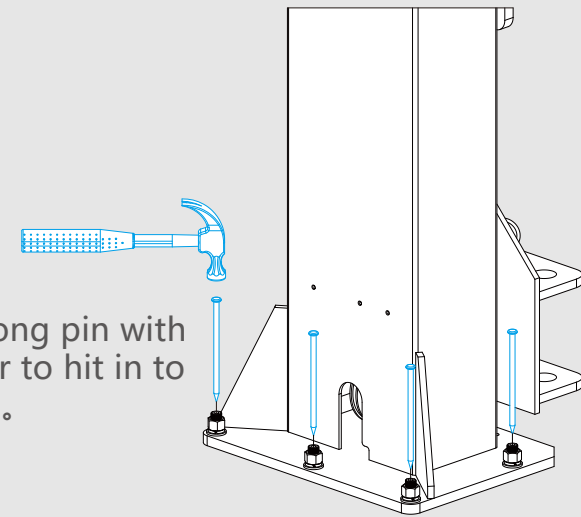

Step 6

To fix well columns.

5 Tighten the screw nuts to be dead.

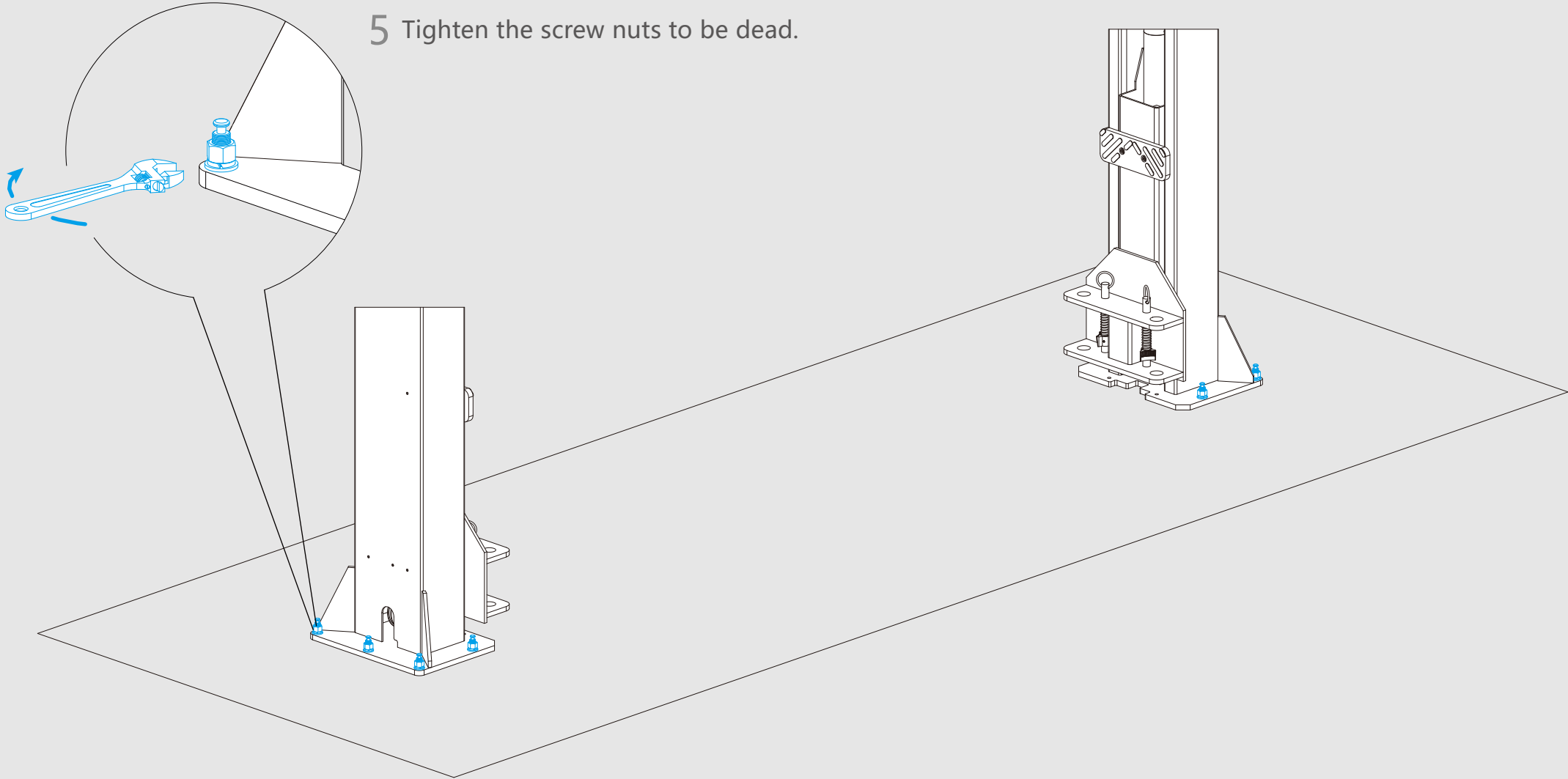

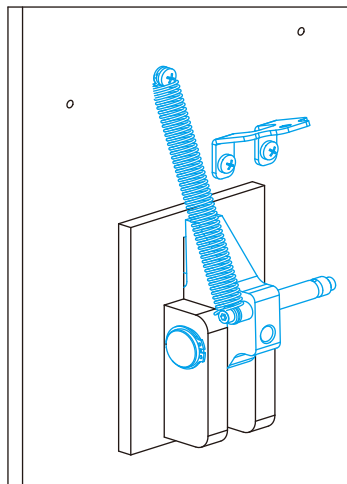
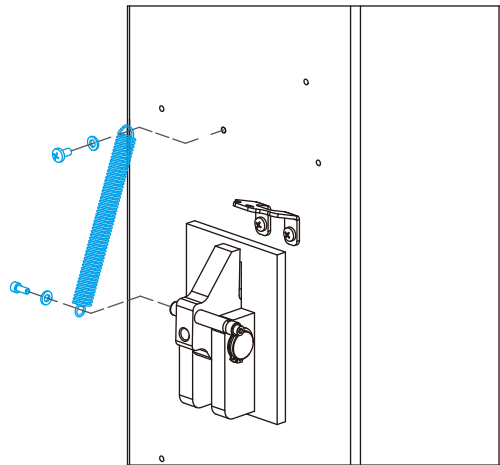
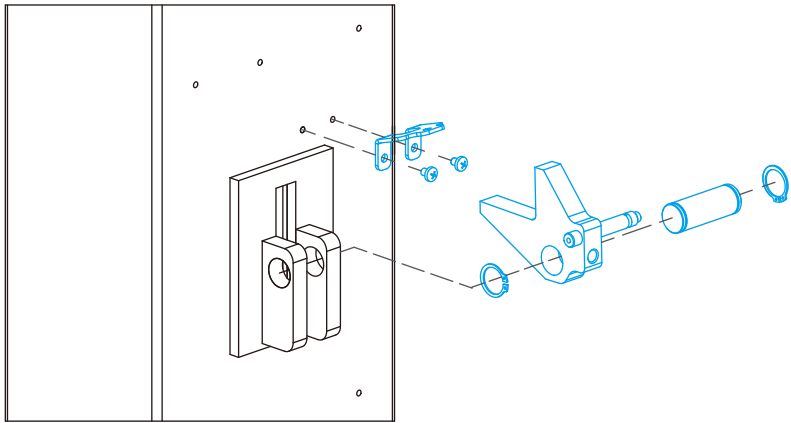

Step 7

To install security lock (command column).

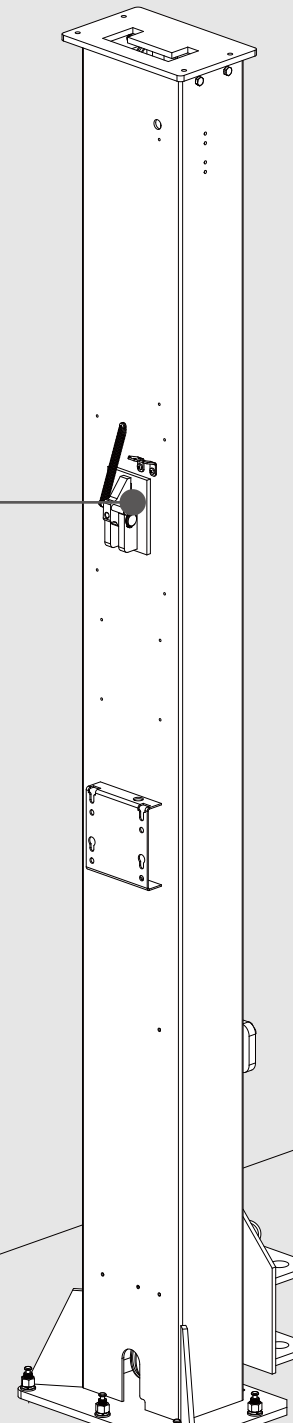

Step 8

To install security lock (slave column).

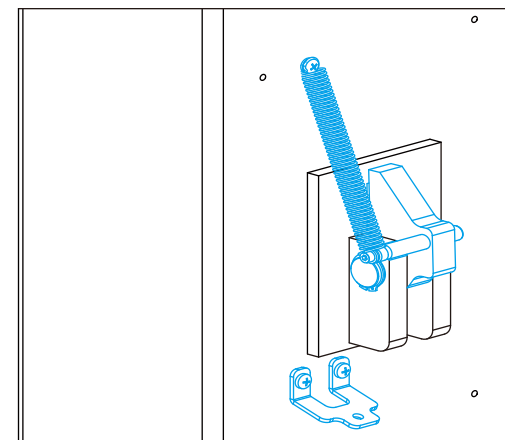
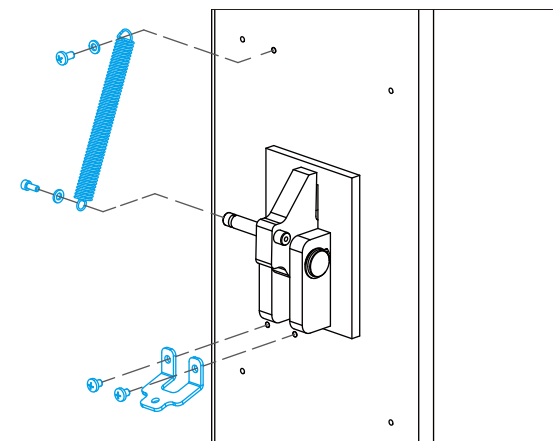
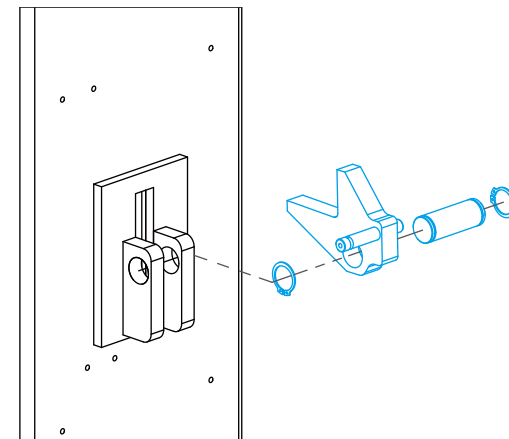
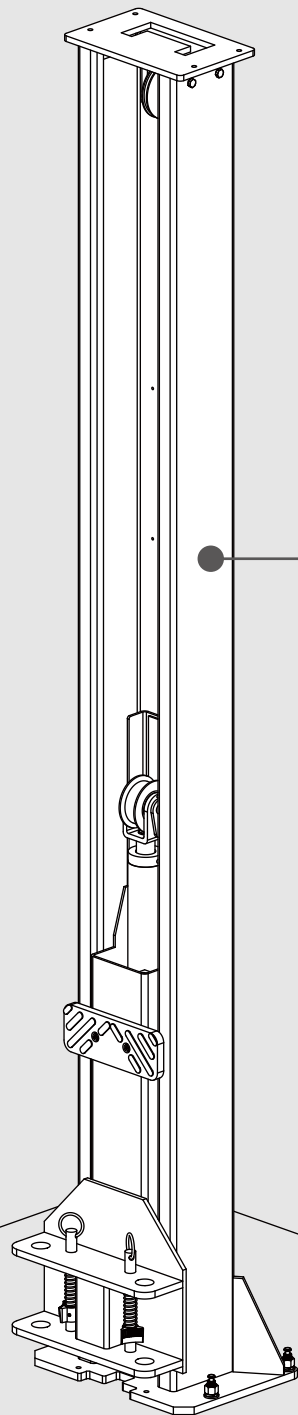

Step 9

To lift up the carriage to the first latch.

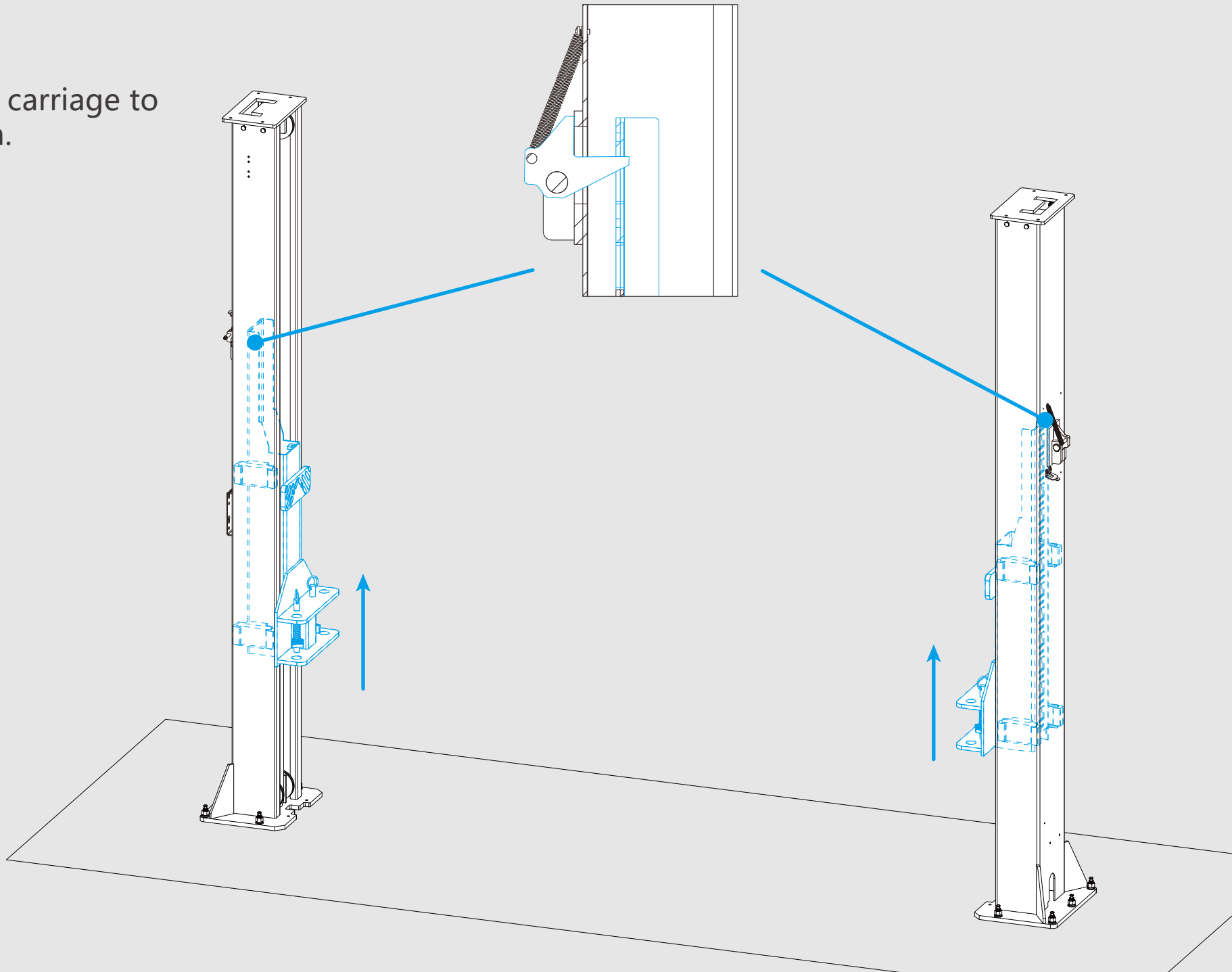

Step 10

To put down U shape protection hood.

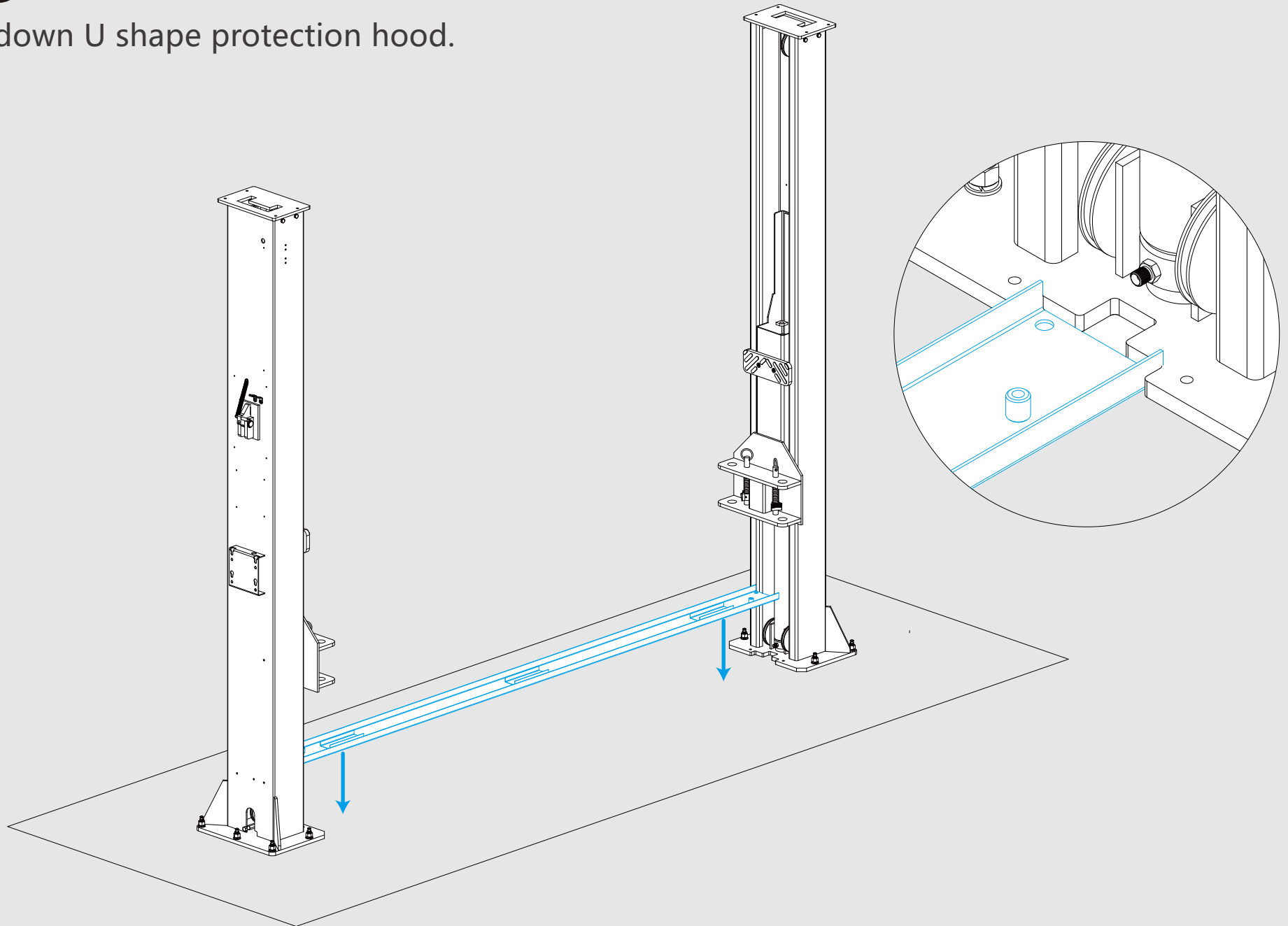

Step 11

To install synchronization cables.

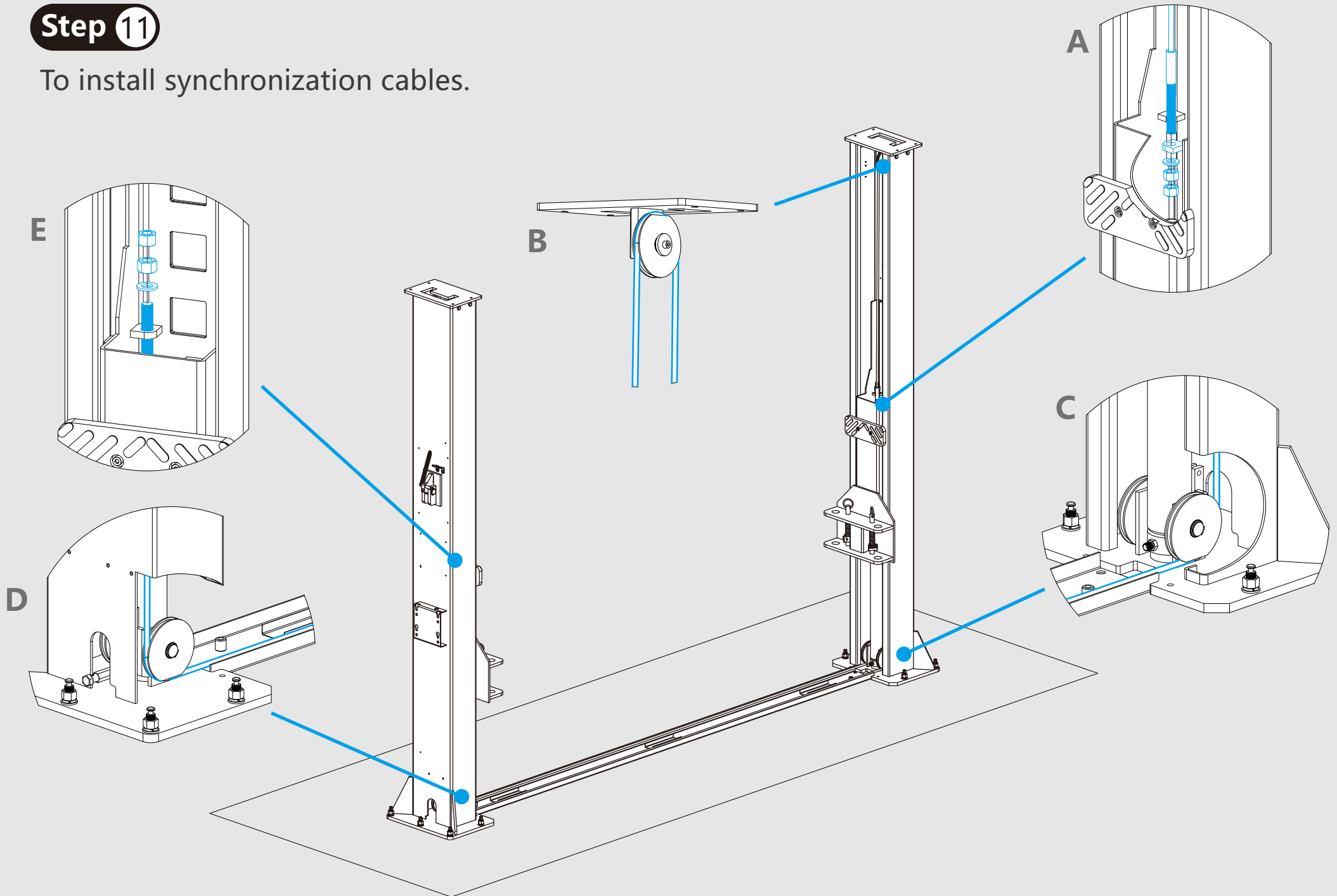

Step 11

To install synchronization cables.

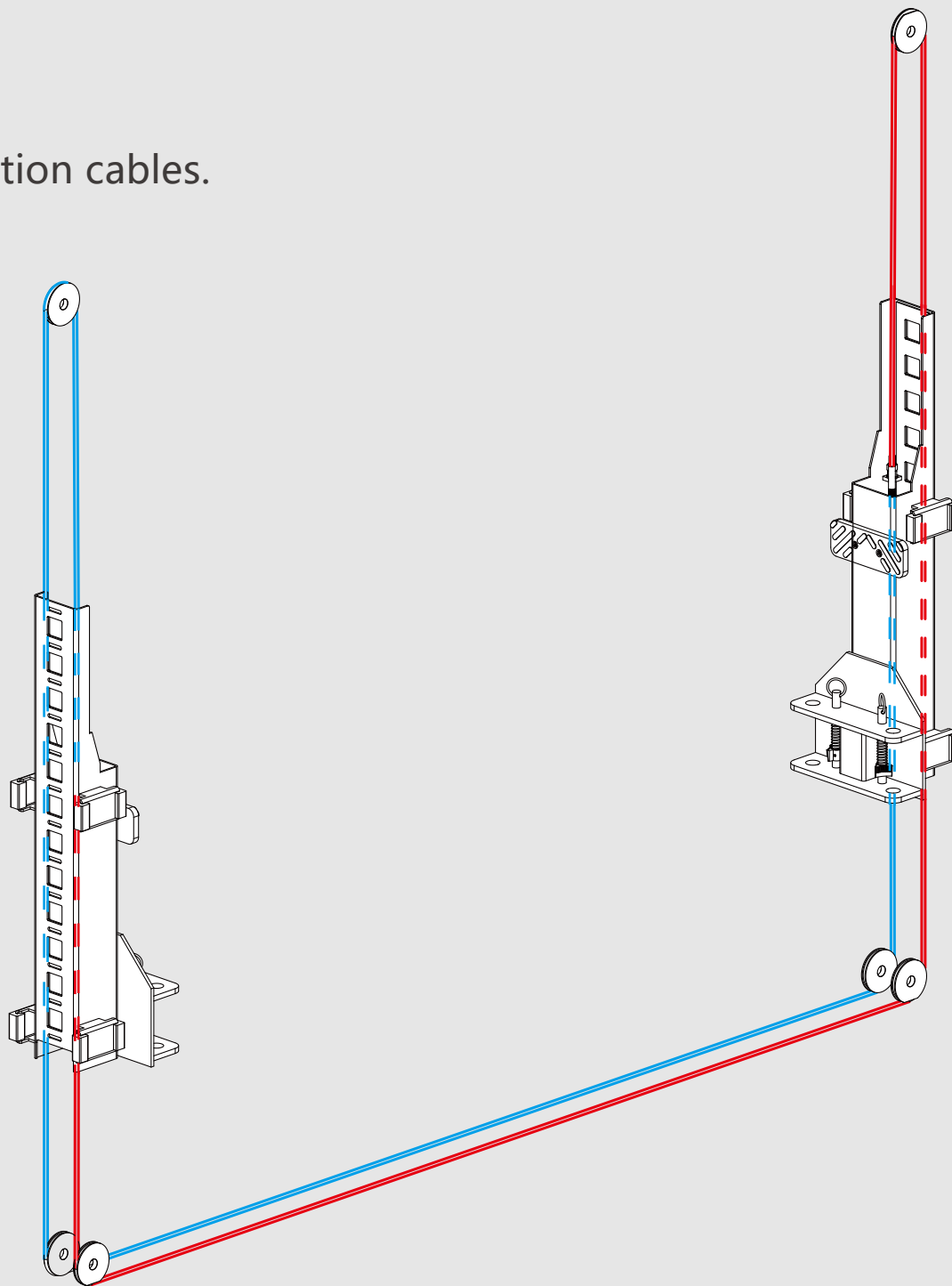

Step 12

To install power unit
and link oil hoses to two cylinders.

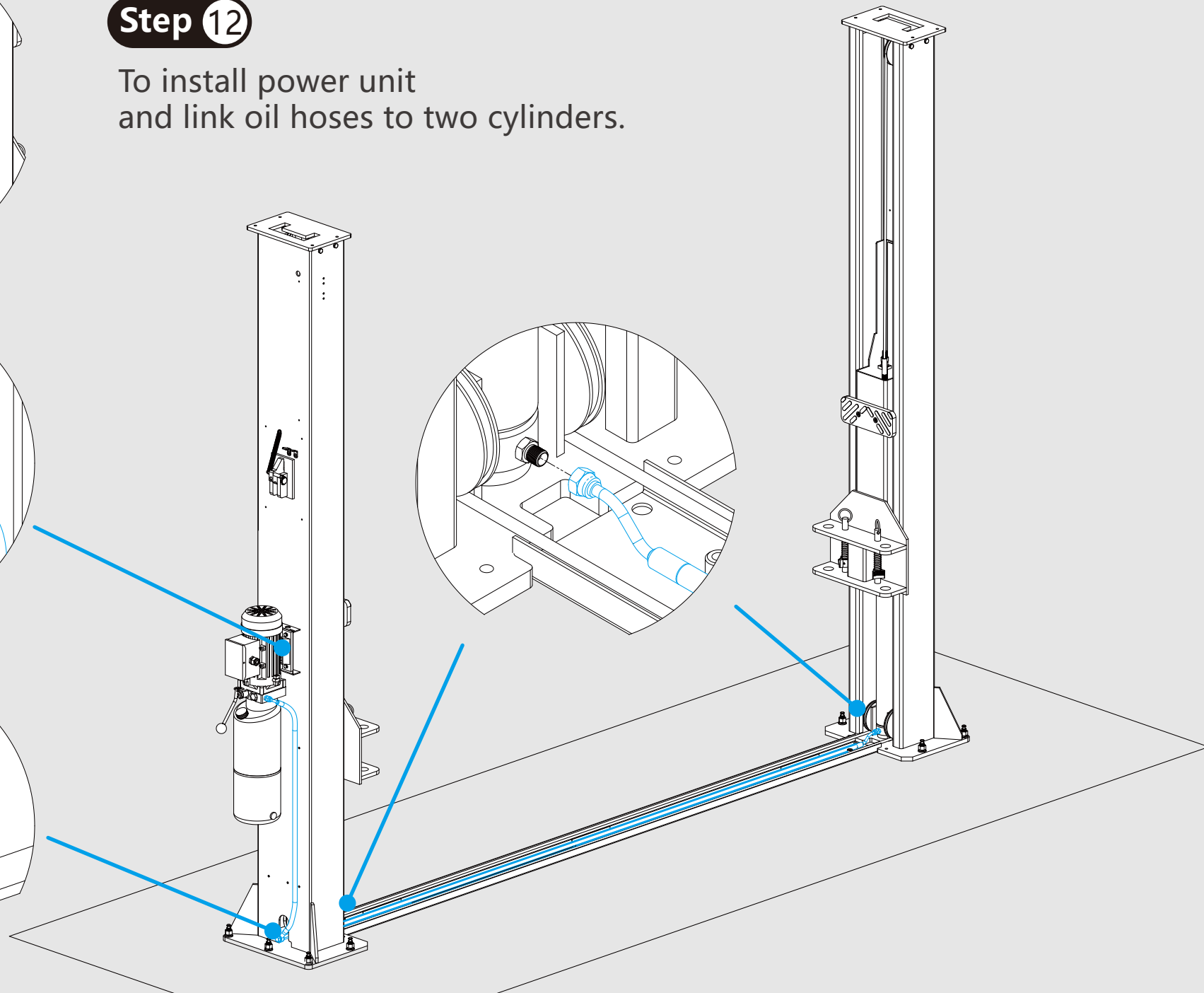
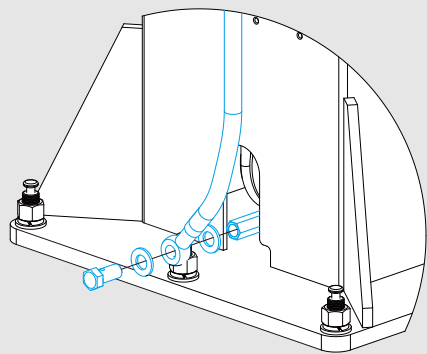
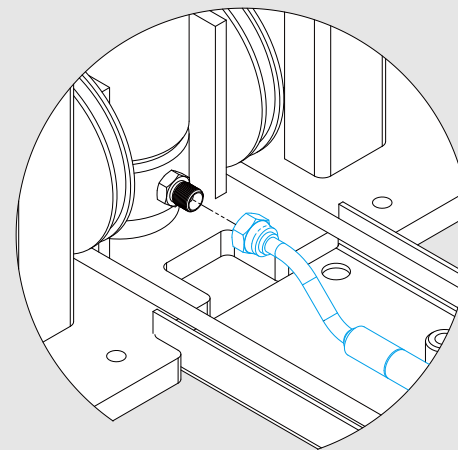
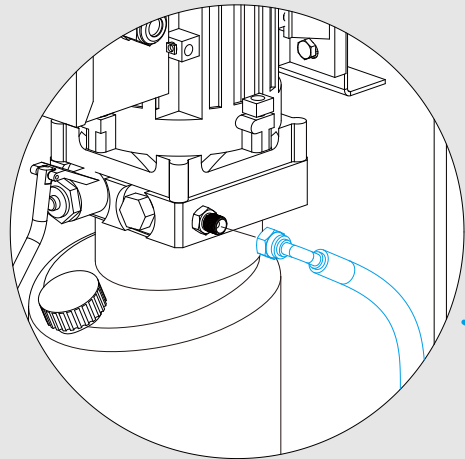
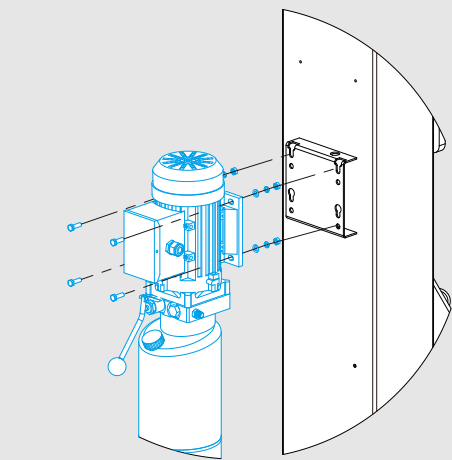

Step 13

To install lock cable.

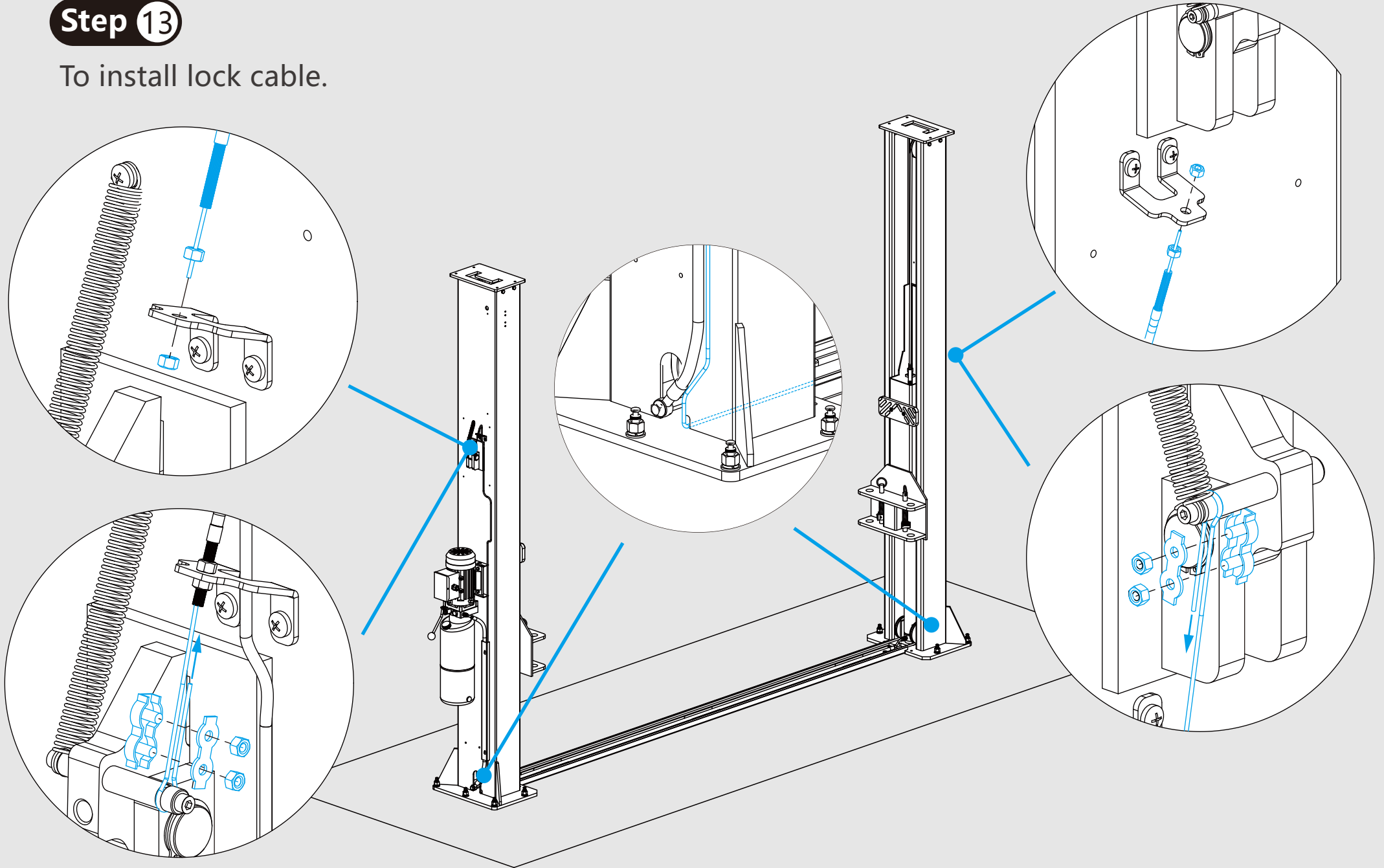

Step 14

To install arms and crossing plate.

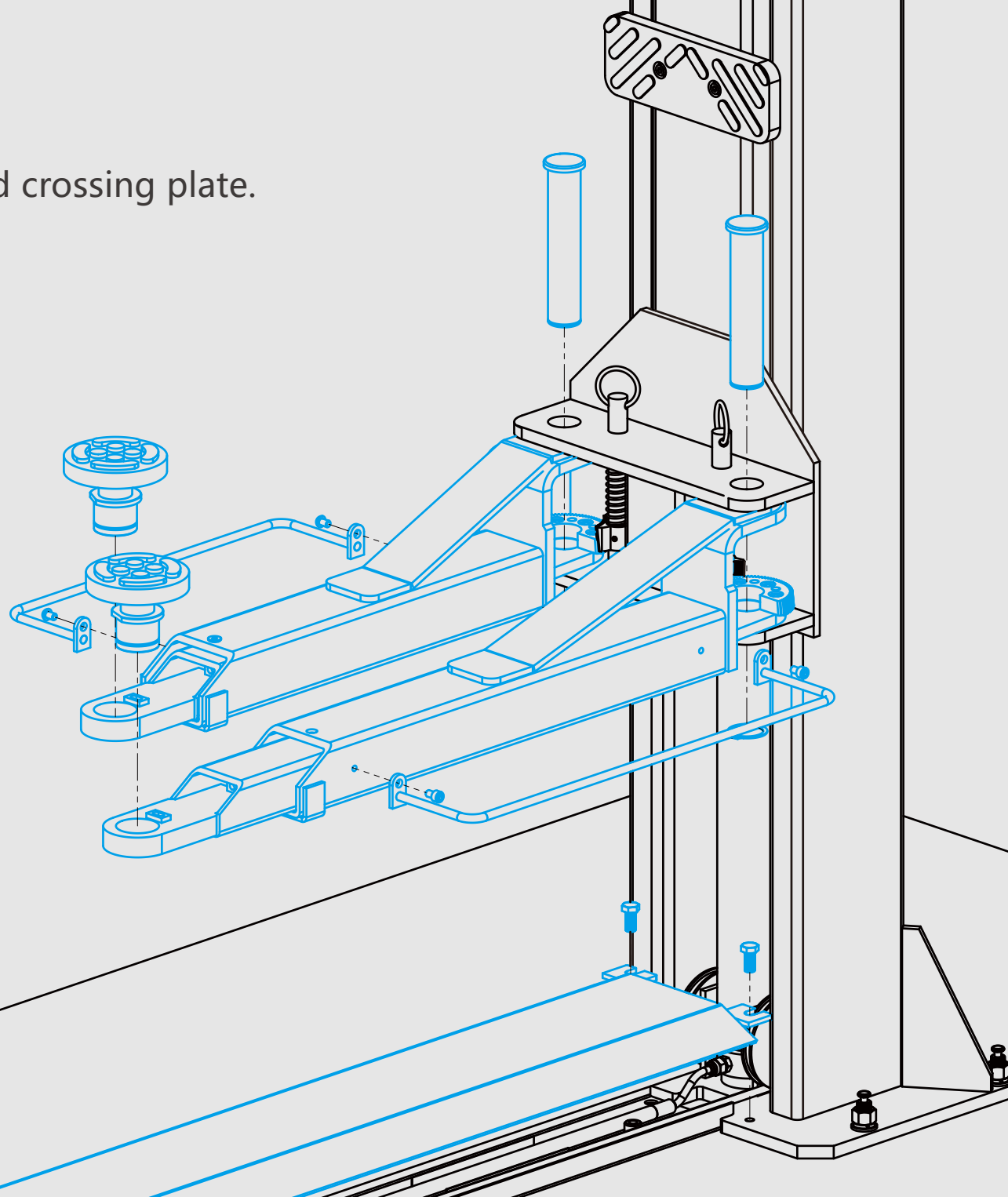

Step 15

To fix control box and up limit switch.

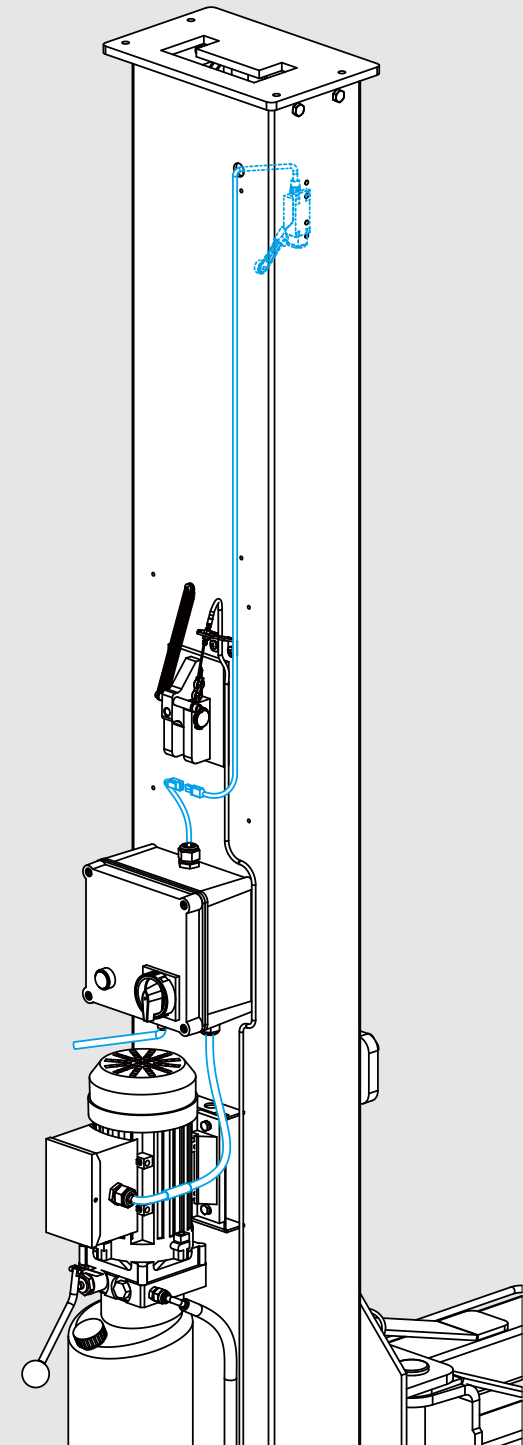
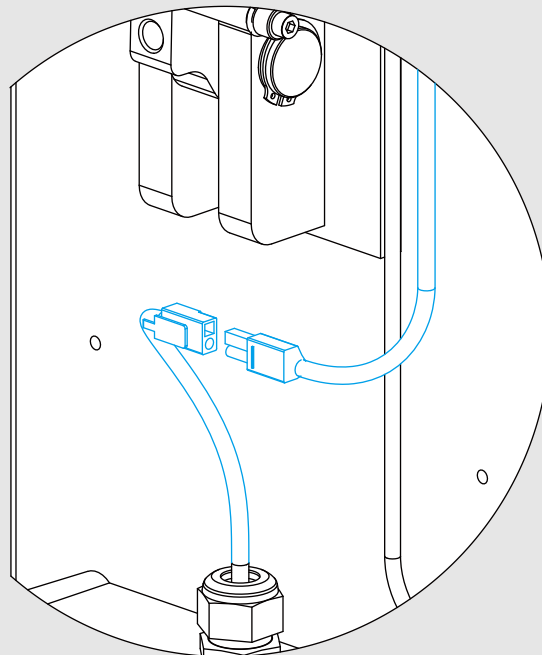
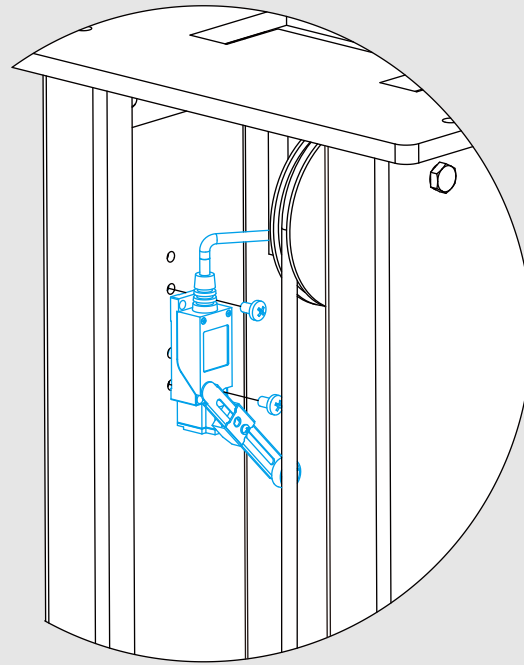
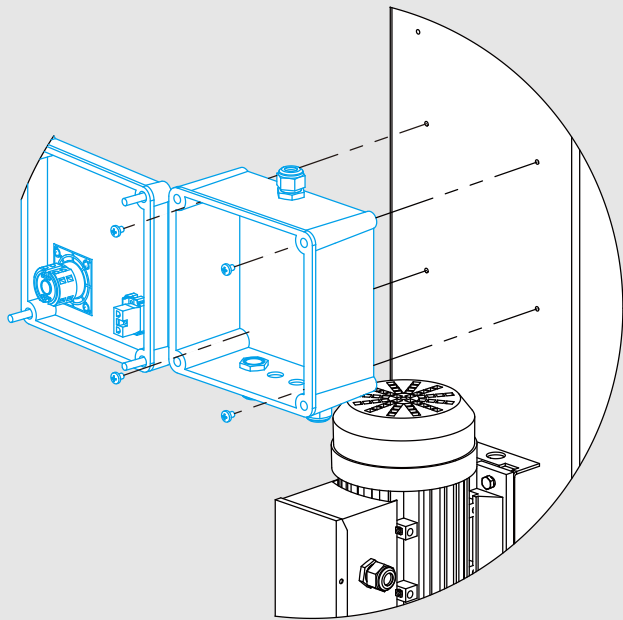

Step 16

To fix oil hose cover
and lock cover.

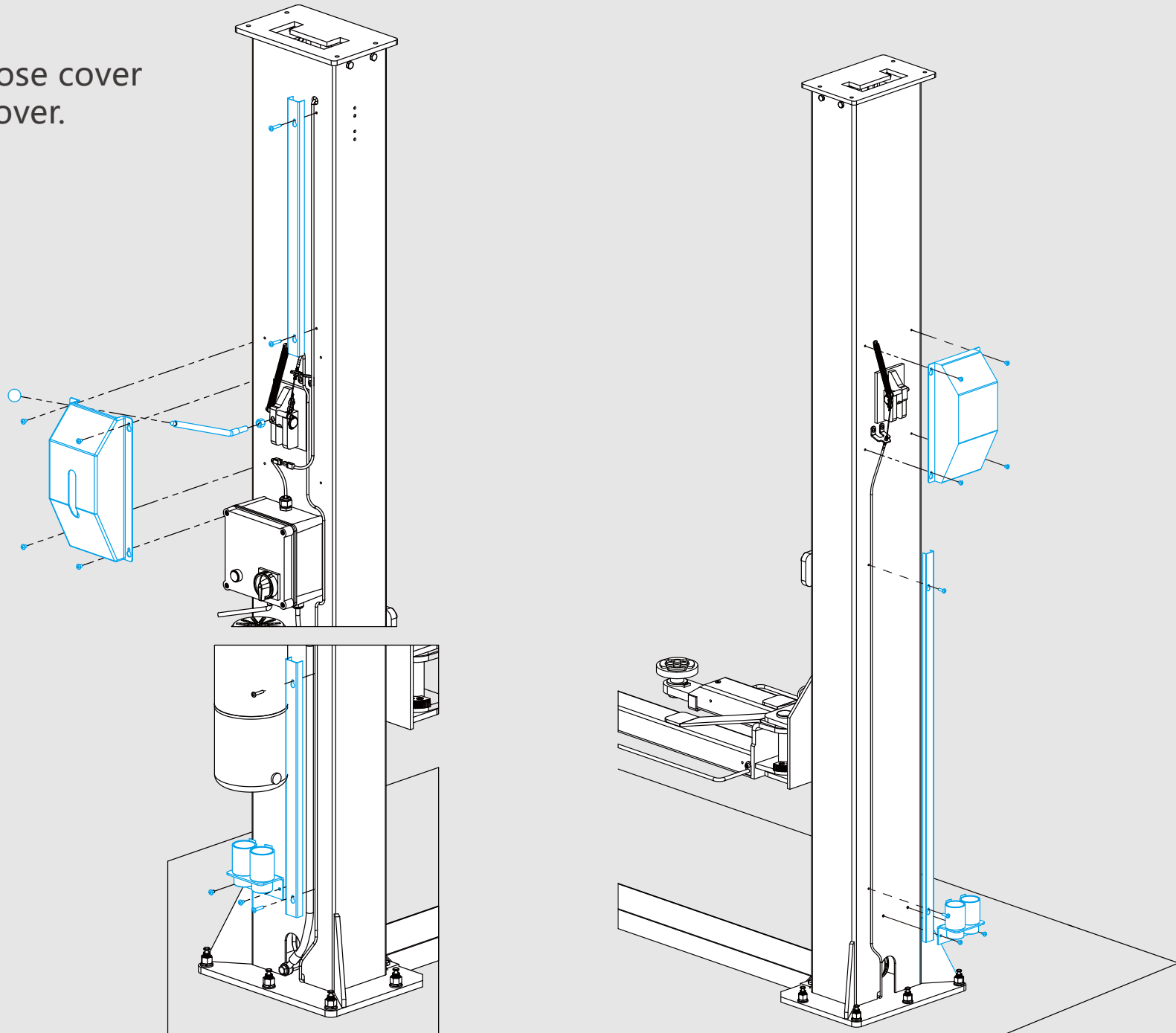

E P L U S™